

Technical Bulletin

[Flat Seam Appearance](#) | [Importance of Proper Number of Stitches & Balance](#) | [Introduction](#) | [Minimize Broken Stitches](#) | [Operator Handling](#) | [Seam Margin](#) | [Type/Size Used to Sew Stretch Knit](#)



Sewing on Stretch Knit Fabrics

Introduction

Most stretch knit garments are seamed with overedge and/or coverstitch seam constructions because these stitches offer both seam elasticity and coverage of the raw edge of the fabric. However, a common quality problem is having broken stitches or "stitch cracking" when the seam is stretch excessively. Generally, the greater the elasticity of the fabric, for example, high Lycra® content, the more likely you are to have broken stitches if you do not understand how to optimize seam elasticity in the stitch.

What Can Be Done to Minimize Broken Stitches?

Most broken stitches are the result of one of the following:

- Not using the correct thread type & size.
- Not having enough stitches per inch.
- Not sewing with the correct stitch balance or thread tensions set incorrectly.
- Not using the correct seam margin.

What Thread Type & Size Are Commonly Used to Sew Stretch Knit Fabrics?

The most common threads used to sew stretch knit fabrics are textured polyester or nylon threads like A&E's [Wildcat Plus®](#) or [Best Stretch®](#). Textured threads are ideal for overedge and coverstitch seams because they offer excellent seam coverage and seam elasticity. Generally, light weight knits are sewn with T-18 or T-24 size threads. Medium weight knits are generally sewn with T-24 and T-35 size threads. Spun polyester threads such as A&E's [Perma Spun®](#) and [Excell®](#) are also used instead of 100% cotton threads because they have a higher elongation offering greater seam elasticity. In cases where the garment is subjected to harsh wash programs, many manufacturers prefer to use [Perma Core®](#) threads.

Why Is It Important To Have the Proper Number of Stitches Per Inch & Stitch Balance?

Seam elasticity can be accomplished by a combination of having the correct number of stitches per inch and having the proper stitch balance. The more stretch the fabric has, the more stitches per inch that are required. Common ranges of stitches per inch are from 12 to 14 spi.

Applying & Releasing Stress Across the Seam

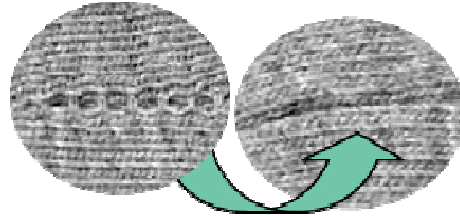

However, even when the correct number of stitches per inch are being used, if the proper stitch balance is not used, you will still experience excessive seam failure. One way of checking the stitch balance is first check the seam for "seam grinning" by pulling perpendicular to the seam.

Pulling the Seam Along the Stitch-line

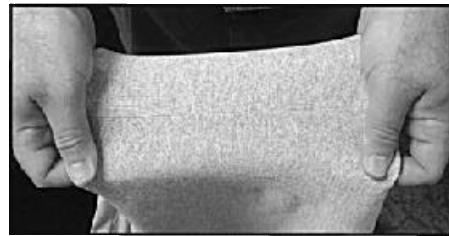

After applying the stress across the seam, remove the stress and check to make sure the seam goes back to a closed seam. Next pull the seam along the stitch-line to the maximum stretch level that the garment will be subjected to and see if the threads fail.

If they do, generally there is not enough needle thread in the stitch. Therefore loosen the needle thread tension and check the seam again.

What You Should Know about Seam Margin

The seam width on overedge and coverstitch seams also has a major factor in producing a seam with the proper seam elasticity. Take a zig-zag stitch for example. The wider the stitch and the more stitches per inch that are used, the greater the seam elasticity.

504 and 514 Overedge Stitching

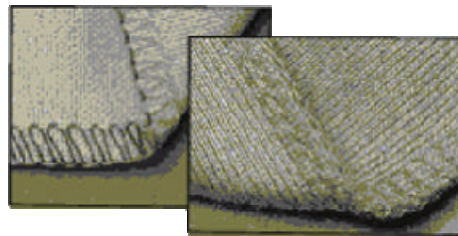

A zig-zag stitch will stretch until it becomes a straight stitch at which time all the stress is applied to the thread.

1/8" and 1/4" Needle Spacing

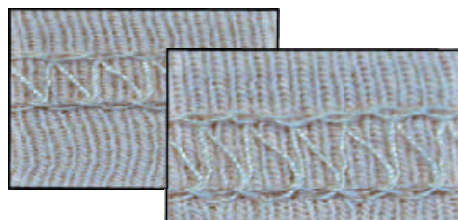

On overedge machines, the chaining finger or "stitch tongue" on the needle plate and the adjustment of the overedge machine's trimming knives determines the seam width.

Seams sewn with a wider "bite" or seam margin and more stitches per inch will have greater seam elasticity.

The two most common overedge stitch formations used for seaming knit garments today include the single needle 504 stitch and the two needle 514 stitch.

Obviously, a two-needle 514 overedge stitch offers greater seam elasticity because this stitch generally is sewn in a wider seam margin. However, many times this wider stitch is not desirable on intimate apparel or knit underwear because it creates a more bulky seam. In this case, a narrow bite 504 stitch is preferred with more stitches per inch and the correct stitch balance.

The needle spacing on a 406 bottom coverstitch types and similar stitch types have a tremendous impact on the seam elasticity.

The wider the needle spacing, the more elasticity the stitch will have at a given stitch length. Therefore, when a narrow needle spacing is desired on high-stretch fabrics, the sewing machine should be set for more stitches per inch to minimize thread failure in the seam.

Making Seams on Stretch Knit Fabrics with a Flat Seam Appearance

Tandem Differential Feed System

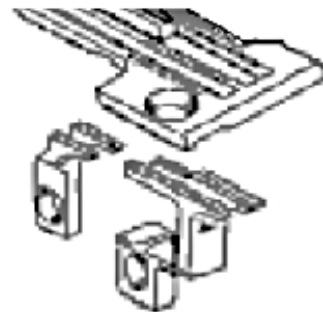

Most sewing machines designed for sewing stretch knit fabrics have a differential feed system that includes two independently driven feed dogs. Tandem differential feed systems have a front differential feed dog and a back main feed dog.

If both feeds are feeding at the same stitch length or if a sewing machine is being used with a single feed, then the resulting seam will appear "wavy" like the ocean.

Setting Differential Feed To Compensate for Fabric Stretch

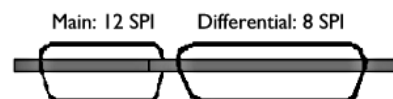

To compensate for the stretch in the fabric, the front differential feed is set to feed more fabric in than the back feed is feeding out resulting in a flat seam appearance.

Most binding or border machines are also equipped with an "off-set" differential